



Bobcat®

One Tough Animal.

DIESEL FORKLIFTS

9-Series, Pneumatic, 4.0 to 5.5 ton capacity

🌐 EMEA



ONE TOUGH ANIMAL

OUR MISSION

We empower operators to accomplish more, while working in the toughest conditions and tightest situations. When our customers have the will, we provide the way.

BOBCAT'S HISTORY

In 1958, Melroe Manufacturing Company introduced a compact front-end loader that evolved quickly into the M400, the world's first true skid steer loader. The company soon adopted what became the world-famous 'Bobcat' brand – and its success paved the way for the global compact equipment industry we know today.



YEARS OF EXPERIENCE

In 2021, Bobcat furthered its reach by acquiring Doosan Industrial Vehicle, increasing its capacity to provide customers with comprehensive business solutions. With Doosan's expertise in material handling and warehouse equipment dating back to its inaugural forklift in 1968, the company has established a global presence, with 400 dealers across 93 countries.



BOBCAT TODAY

Now, with a diversified portfolio that includes forklifts and warehouse equipment, Bobcat serves as a one-stop solution for intralogistics needs, from loading shipping containers to optimizing warehouse operations. Produced in its South Korean factory, Bobcat's material handling machines offer the precision and durability customers expect.



TOUGH, AGILE & SAFE

DESIGNED FOR PRODUCTIVITY

Bobcat's D45SC-9 Series Forklifts come packed with powerful engines, intuitive controls, comfortable operation, and top-notch safety features. Our trucks are built tough to enhance your business productivity while keeping costs in check, thanks to a low cost of ownership.



POWERFUL AND EFFICIENT
Get more done daily thanks to the high-performance engine that delivers up to 55 kW of power at 2 300 rpm. Boost your productivity with high driving/travel speed. **P. 6-7**



COMFORTABLE ALL SHIFT LONG
Enjoy the comfort of a spacious cab with plenty of leg room, increased head room, a wide Sears & Grammer seat, and tons of convenience features as standard. **P. 8-9**



SAFETY FIRST
Protect your investment, workforce, and handled goods with excellent all-around visibility, reverse lock brakes, and a host of other standard safety features. **P. 10-11**



RUGGED RELIABILITY
Discover the perfect blend of power, performance, and functionality with features like an IP65-rated connector, oil-cooled disc brakes, and enhanced cooling performance. **P. 12-13**

OUTSTANDING PRODUCTIVITY



▶ IMPROVED PRODUCTIVITY

Bobcat's 9-Series forklifts outshine competitors with exceptional driving speeds, drawbar pull, and gradeability, ensuring swift and efficient operations.

▶ CUSTOMIZED PERFORMANCE

Tailor your performance with 3 distinct torque modes: Eco mode optimizes fuel efficiency, Standard mode handles typical tasks, and High mode boosts the truck's capability for heavy-duty operations.



▶ HYDRAULIC CONTROL

Experience the convenience of hydraulic control for lifting and tilting, providing efficient and precise handling for all of your material transport needs.

▶ OIL-COOLED DISC BRAKES

Enjoy oil-cooled disc brakes for better braking and faster cycles, giving you the confidence to navigate and stop quickly. This enhancement speeds up task completion significantly – boosting overall productivity.

COMFORT & CONTROLS



▶ GREAT VISIBILITY

Benefit from improved operator visibility in all working positions, thanks to a wider mast window, repositioned hydraulic hoses, and a flat bar-style overhead guard.



▶ DELUXE SUSPENSION SEAT

The deluxe suspension seat prioritizes operator comfort with both lever and fingertip controls. Offering customizable comfort, the seat features a larger recline, extended seat adjustment range, and weight resistance.



▶ SPACIOUS OPERATOR COMPARTMENT

The cab's ample leg room, adjustable steering column, and ergonomic operator pedals ensure ease of entry and exit for the operator.



▶ CONVENIENT FINGERTIP CONTROL

Work long shifts comfortably with fingertip controls, designed to reduce operator fatigue while ensuring efficient, precise, and comfortable operation.

▶ CONVENIENCE TRAY



With a standard USB port and optional features – such as a cup holder, document clipboard, and interior lighting – the operator enjoys added convenience in every task.

▶ MORE HEAD ROOM



The lowered floor plate increases torso clearance by 26 mm, providing the operator with more head space.

▶ FULL-COLOR DISPLAY WITH REAR-VIEW CAMERA



Enjoy a standard 5-inch (optional 7-inch) display panel that is bright, clear, and highly visible outdoors, keeping the operator informed about the machine's conditions.



SAFETY IN EVERY MOVE

▶ ADVANCED PROTECTION FOR YOU AND YOUR OPERATION

Bobcat forklifts have safety embedded in their DNA. Packed with tons of features that protect people, workplaces, and your investment, our machines provide peace of mind in every task, every day.

▶ REAR DETECTOR

The rear detector alerts the operator to obstacles behind the vehicle when traveling in reverse.



▶ ELECTRIC PARKING BRAKE (EPB)

The parking brake engages automatically to keep the vehicle stationary when the operator exits the seat.



▶ BACKUP ALARM

The backup alarm emits a warning signal when the operator is driving in reverse, alerting those in the nearby vicinity.



▶ REVERSE LOCK

The reverse lock allows the operator to change directions from forward to reverse only when the machine's speed is less than 3 km/h, ensuring smoother transitions.



▶ WEIGHT SCALE

With the help of an integrated weight scale, operators can prevent truck overload, keeping the workplace safer and more secure.



▶ GROUND SPEED CONTROL

Setting a speed limit prevents the truck from going too fast. This limit can be customized for both forward and reverse directions.



▶ REAR GRAB BAR WITH HORN

The rear grab bar provides stability during reverse maneuvers and tight space navigation. Plus, the horn can be easily activated with the push of a button conveniently located on the bar.



▶ REAR-VIEW MIRROR

The rear-view mirror provides more visibility, preventing accidents while reversing, and avoiding collisions with objects and pedestrians.

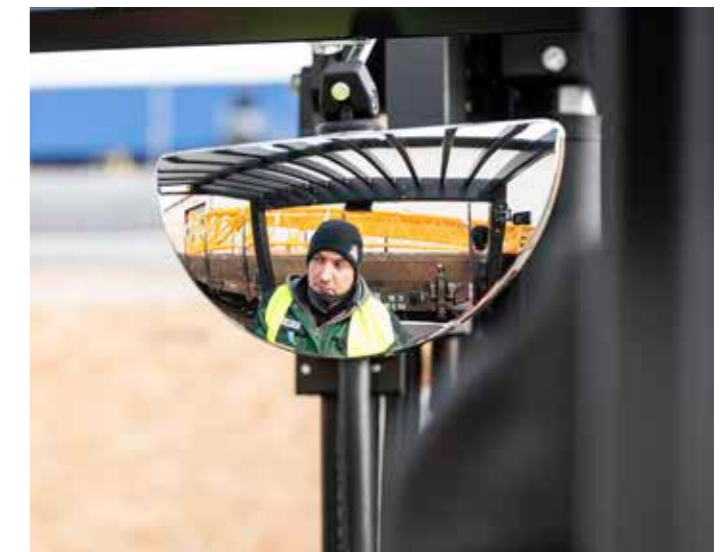

BUILT TO LAST

▶ A HERITAGE OF RELIABILITY

The impressive cooling capacity, extended service intervals, and maintenance-free engine are designed to minimize maintenance costs. Meanwhile, the robust frame, fully floating drive axle, and oil-cooled brakes ensure years of continuous productivity, day after day.



THERE'S NO TIME FOR DOWNTIME. STAND UP TO EVERY TASK THAT COMES YOUR WAY, DAY AFTER DAY.

2 YEAR WARRANTY

▶ WARRANTY

Bobcat develops every machine to the highest standards of quality and durability. That's why our standard warranty provides 24 months or 2 000 operating hours (whichever occurs first) of coverage.



▶ PROTECTION PLUS EXTENDED WARRANTY

Enjoy total peace of mind with Protection Plus extended warranty. Providing the same level of protection as the standard warranty, Protection Plus also reflects different customer needs and expectations by offering a choice of durations and annual operating hours.

▶ EXTENSIVE DEALER NETWORK

You can rely on our network of dealers and service partners who are always ready to help you.

▶ BOBCAT GENUINE PARTS

Quality components delivered to our dealers guarantee that all of our equipment is built to last, withstand the toughest conditions, and provide reliable performance.

MAIN SPECIFICATIONS

TECHNICAL DATA ACCORDING TO VDI 2198							
		D50C-9	D55C-9	D40SC-9	D45SC-9	D50SC-9	D55SC-9
Drive		Diesel					
Load capacity (kg)	Q	5 000	5 500	4 000	4 500	5 000	5 500
Load center (mm)	c	600		500			
Load distance: center of driveaxle to fork (mm)	x	570		560			
Wheelbase (mm)	y	2 115		2 015		2 115	
Service weight (kg)		6 930	7 300	5 795	6 100	6 530	6 930
Tread, front (mm)	b11	1 155 / 1 290		1 140 / 1 290		1 155 / 1 290	
Tread, rear (mm)	b12	1 115					
Tilt of mast / fork carriage forward / backward (°)	α/β	8 / 10					
Height, mast lowered (mm)	h1	1 985 – 4 045		2 095 – 3 115		1 985 – 3 770	1 985 – 4 045
Free lift (mm)	h2	165 – 1 820		155 – 2 370		155 – 2 085	165 – 1 820
Maximum fork height (mm)	h3	2 750 – 5 925		3 000 – 7 000		3 000 – 6 500	
Height, mast extended (mm)	h4	4 160 – 7 350		4 260 – 8 275		4 410 – 7 925	4 160 – 7 350
Height of overhead guard (mm)	h6	2 230		2 225		2 230	
Height of seat (mm)	h7	1 225		1 220		1 225	
Overall length (mm)	l1	4 530	4 560	4 160	4 200	4 480	4 530
Length to forkface (mm)	l2	3 300	3 340	2 995	3 000	3 260	3 300
Overall width (mm)	b1	1 455		1 370		1 455	
Fork dimensions (mm)		50 × 150 × 1 200		50 × 150 × 1 050		50 × 150 × 1 200	
Fork carriage width (mm)	m1	1 330		1 250		1 330	
Ground clearance, loaded, below mast (mm)	m1	160		150		160	
Ground clearance, center of wheelbase (mm)	m2	205					
Aisle width for pallets 1 000 × 1 200 crossways (mm)	Ast	4 640	4 670	4 515	4 560	4 610	4 640
Aisle width for pallets 800 × 1 200 crossways (mm)	Ast	4 840	4 870	4 715	4 760	4 810	4 840
External turning radius (mm)	Wa	2 870	2 900	2 755	2 800	2 850	2 870
Travel speed, loaded / unloaded (km/h)		24 / 26					
Lift speed, loaded / unloaded (mm/s)		0.53 / 0.6	0.52 / 0.6	0.56 / 0.6	0.55 / 0.6	0.54 / 0.6	0.53 / 0.6
Lowering speed, loaded / unloaded (mm/s)		0.45 / 0.5					
Max. drawbar pull, loaded (kg)		3 754	3 732	3 824	3 762	3 770	3 754
Max. gradeability, loaded (%)		31.5	29	43	38.5	35	31.5
Service brake		foot/hyd					
Engine manufacturer/type		HDI DM03					
Engine power according to DIN ISO1585 (kW)		55.4					
Rated speed (min-1)		2 300					
Torque at 1/min (N•m)		360 @ 1 400					
Number of cylinders / displacement (-/cm³)	cc	4 / 3 409					
Fuel consumption according to VDI cycle (l/h)		5.2					

Specification values in this sheet have been rounded. Performance may vary depending on operating conditions. Products and specifications are subject to improvement and change without prior notice.

(1) Mast dimensions refer to a range from the lowest to the highest available mast with load backrest.

Note: Load capacities are based on the standard chassis without a side shifter.

STANDARD EQUIPMENT & OPTIONS

STANDARD EQUIPMENT & OPTIONS	
PRODUCTIVITY	
Power steering	✓
High powered, fuel efficient engine	✓
Multi-torque mode (Eco/Std/High)	✓
Electronic transmission	✓
Autoshift controller	✓
Auto tilt leveling	•
Mono pedal	•
ERGONOMICS	
Excellent visibility	✓
Large entry grip bar	✓
Anti-slip step plate	✓
Adjustable steering column	✓
USB port	✓
Steering wheel knob	✓
Large rear-view mirror	✓
Full color 5-inch display	✓
Full color 7-inch display	•
Fingertip	•
NFC tag start	•
High full cab (100 mm higher)	•
Rear grab bar with horn	•
Heater & air conditioner for full cab	•
Radio and MP3 for full cab	•
Premium suspension seat	•
Operator fan	•
Tilting roof	•
Cup holder	•
Interior lighting	•
SERVICEABILITY	
Dual element air cleaner and rain cap	✓
Centralized fuse and relay box	✓
Easily opened side covers and floor plates	✓
Easy access to components	✓
EasyView (software to adjust parameters)	✓
Fuel cap with key	•

STANDARD EQUIPMENT & OPTIONS	
SAFETY	
Electronic parking brake	✓
Automatic deceleration	✓
Overhead guard	✓
Operating Sensing System (OSS)	✓
Ground speed control	✓
Reverse lock	✓
Speed limit	✓
Seat belt interlock	•
Lift eyes	•
Seat belt interlock	•
LED combination lights	•
Rear safety light	•
Emergency lamp and switch	•
Backup alarm	•
Zone light (red, blue)	•
Panoramic mirror	•
Rear-view camera	•
Overhead guard with top cover	•
Auto tilt leveling	•
RELIABILITY	
Oil-cooled disc brakes (ODB)	✓
Great cooling performance	✓
Longer service intervals	✓
Heavy-duty radiator	✓
Radiator cover on the counterweight	✓
Service notification	✓
High-speed fan	✓
Precleaner	•
Vented side panel	•
Belly plate	•

*This list is based on factory data. Standard or optional can vary for specific countries.

• = option
 ✓ = standard
 – = not available

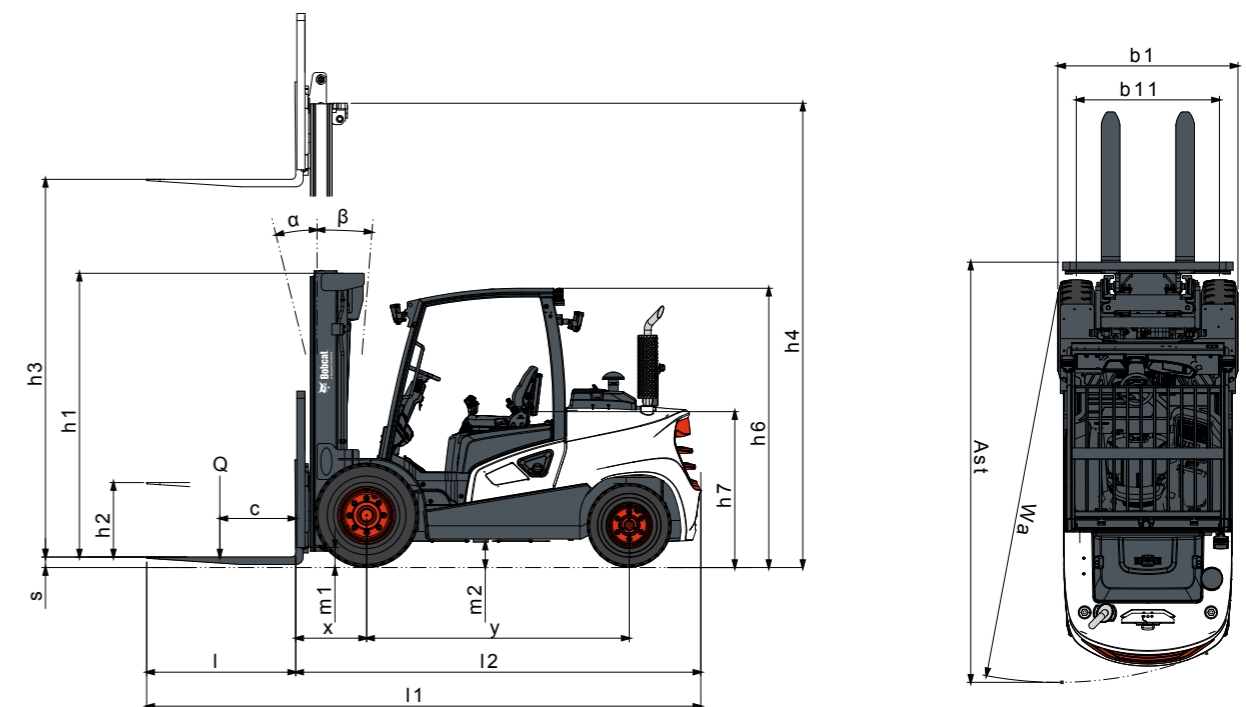

FINANCING OPTIONS

24, 36, OR 48 MONTH FINANCING*

Take advantage of 24, 36 or 48 month financing programs starting from **0% interest** and improve your cashflow.

Ask your dealer for the financing offers available.

340 MACHINES / 150 ATTACHMENT FAMILIES / 1 TOUGH ANIMAL



**SKID-STEER
LOADERS**



**COMPACT TRACK
LOADERS**

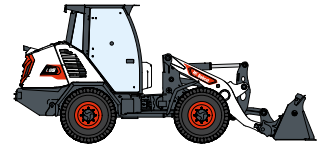

**COMPACT WHEEL
LOADERS**



FORKLIFTS

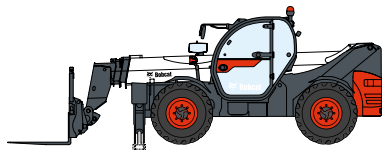

TELEHANDLERS

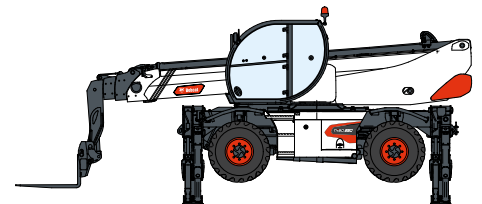

ROTARY TELEHANDLERS



**LIGHT COMPACTION
EQUIPMENT**



**COMPACT
EXCAVATORS**



**COMPACT
TRACTORS**

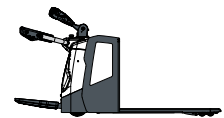

**WAREHOUSE
EQUIPMENT**



**MINI TRACK
LOADER**



MOWERS



**PORTABLE
POWER**

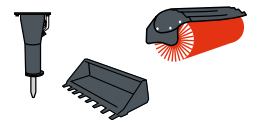

ATTACHMENTS

DOOSAN

Bobcat is a Doosan Company. Doosan is a global leader in construction equipment, power & water solutions, engines, and engineering proudly serving customers and communities for more than a century. | Bobcat and the Bobcat logo are registered trademarks of Bobcat Company in the United States and various other countries. ©2024 Bobcat Company. All Rights Reserved.

www.bobcat.com

©2024 BOBCAT B4502830-EN (04-24)



Bobcat®

*Financing options may vary by country and dealer. Always ask your dealer about currently available financing options. Terms and conditions may apply.

Doosan Bobcat EMEA, U Kodelky 1810, 263 12 Dobříš, Czech Republic